

# M29 SELECT TALL VERSION FOR HIGH CUPS



Compact machine, 2-group, automatic shot dosing, automatic boiler refill, built-in volumetric pump, 2 stainless steel steam arms, hot water tap with hot water economizer, it is possible to accommodate up to 8 ounces cups (max height 3.94 inches).

## LA CIMBALI

ESPRESSO COFFEE AND CAPPUCCINO PROFESSIONAL MACHINES SINCE 1912

To be the world leading manufacturer and distributor of professional espresso coffee equipment, by offering a superior quality product range supported by a capillary after-sales service.

To significantly contribute to the worldwide development of specialty coffee culture by delivering to the consumer the best espresso coffee based experience through relationships with customers based on mutual respect and on common long term goals.

SERVINGS	
Portion size .....	Your figures .....
Selling price .....	.....
Less food cost .....	.....
Profit .....	.....
Multiply serving per day	X .....
Profit per day .....	.....
Multiply days open per year	X .....
Profit per year .....	.....

Please, use the above chart to check your own profit potential.

# M29 SELECT TALL VERSION FOR HIGH CUPS

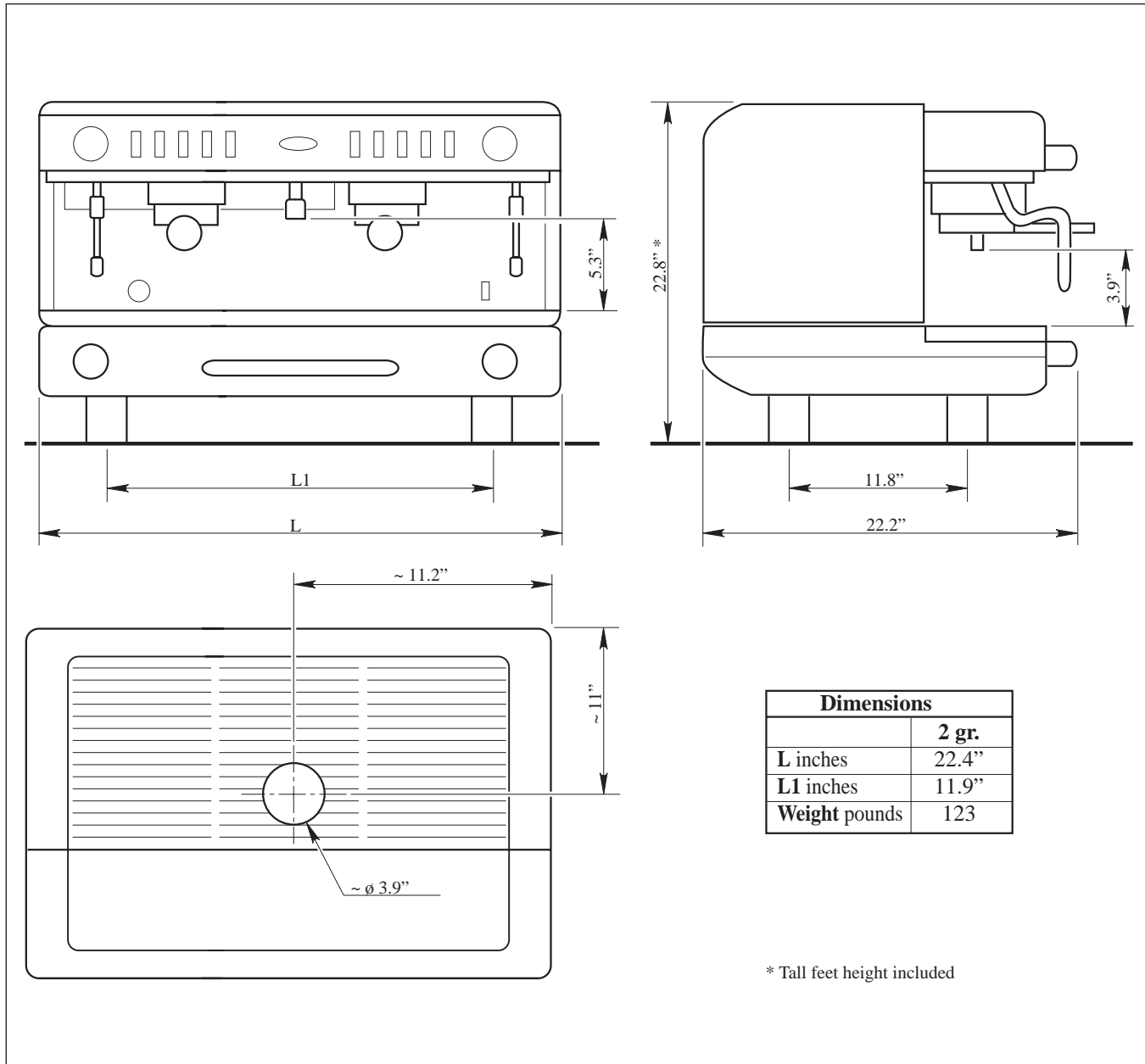

The manufacturer reserves the right to modify the appliances presented in this publication without notice.

<b>Voltage:</b> 208-240V <b>Max Power:</b> 2700-3600W 20 Amps single-phase	<b>Width</b> .....22.4 inches <b>Height</b> .....22.8 inches <b>Depth</b> .....22.2 inches  <b>Weight</b> .....123 pounds  <b>Boiler capacity</b> .....1.3 gal.	<b>Compact machine</b> 2-group automatic shot dosing automatic boiler refill built-in volumetric pump 2 stainless steel steam arms hot water tap with hot water economizer it is possible to accomodate up to 8 ounces cups (max height 3.94 inches).
---	---	--

**LA CIBALI**

Cimbali S.p.A. Via A. Manzoni 17 - 20082 Binasco (MI) - Italy  
 www.cimbali.it - cimbali@cimbali.it  
 Toll Free: 1-800-7 CIBALI